

 GATERON <i>GATERON Electronic Technology Co.,Ltd</i>		<h1>产品规格书</h1> <h2>Product Specification</h2>	
编 号 No.:	SPEC-KS-33-042	总页数 Pages:	8
版 本 Version:	1	发出日期 Issued on:	2026-03-12

客户名称 Customer:	
客户部件号 Customer Part No.:	
佳达隆产品名称 GATERON Product Name:	Keyboard Switch(青竹轴)
佳达隆产品型号 GATERON Item No.:	KS-33C10B060NN-D545 (自润)

规格书确认 Specification For Approval	
确认者 Approval by	
签名或盖章 Signature: _____	日期 Date: _____

备注:
1. 该规格书为客户与佳达隆公司产品在技术方面的共识，其它相关数据上与该规格书不一致的内容都是无效的。 This Product Specification is considered as the technical agreement on product between the receiving customer and GATERON. Any information on the Product Catalogue which is in conflict with or different from the corresponding information of this document is considered as invalid.
2. 如果顾客收到规格书后没有信息反馈而直接向我公司订货，我们将认为贵客已接受此规格书。 If customer issue purchase orders without confirmation by signature of this specification after receipt, such confirmation will be considered as granted upon receipt of the first purchase order.
3. 本产品规格书从生效日起1年后，如果没有订货返回或再次申请最新规格书时请作无效处理。 If there is no order or no request for new specification after 1 year upon this specification is issued, the specification will be regarded as invalid.

若确认此规格书，请签复此页。Please return this copy as a certification of your approval.

规格书更改记录 Record of Changing Specification			
规格书项 Item of Spec.		规格书项 Item of Spec.	
更改前 Before Change		更改前 Before Change	

地址: 广东省惠州市仲恺高新区中韩(惠州)产业园松北路1号
Address: No. 1, Songbei Road, China - Korea (Huizhou) Industrial
Park, Zhongkai High tech Zone, Huizhou City, Guangdong
Province, China
电话 Tel: 0752-3823398 (Chinese) 86-752-3823398 (International)
传真 Fax: 0752-3823368
电子邮箱 E-Mail: dm@gateron.com

拟制 Prepared by: Wang Bolin
审核 Checked by: Fu Dong
批准 Approved by: Song JianQing

产品型号 Item.	KS-33C10B060NN-D545	说明 Description	Keyboard Switch	版本 Version	1
页 码 Page	第 2 页 2 of 8		日期 Date	2026-03-12	

1. 一般特性 General Characteristics:

1.1 适用范围 Application	该规格书指开关的一般使用范围 This specification is applied to the switch for general applications.
1.2 使用温度范围 Operating Temperature Range	-40 °C 到 +80 °C -40 °C to +80 °C
1.3 使用相对湿度范围 Operating Relative Humidity Range	≅85% RH, +40 °C
1.4 实验条件 Test Conditions	若没有特别说明, 则试验大气条件如下: Unless otherwise specified, the atmospheric conditions for making measurements and tests are as follows: 环境温度 Ambient Temperature: 5-35°C 大气压力 Air Pressure: 86-106 Kpa 相对湿度 Relative Humidity: 45-85% RH

2. 外观, 结构及尺寸 Appearance, Structure and Dimensions:

2.1 外观 Appearance	产品外观良好, 无锈蚀、裂纹和镀层缺陷。 The switch shall have good finishing, and no rust, crack or plating defects.
2.2 结构及尺寸 Structure and Dimensions	参见产品图纸。 Refer to individual product drawing.
2.3 标识 Markings	参见产品图纸。 Refer to individual product drawing.

3. 额定负荷 Ratings:

额定负荷 Ratings	10mA 12VDC (Resistance load)
--------------	------------------------------

4. 电气性能 Electrical Characteristics:

项目 Item	标准 Criteria	实验方法 Test Method
4.1 绝缘电阻 Insulation Resistance	100MΩ Min.	在相互绝缘的所有端子之间及各接线端子与外露的非载流金属零件之间加载 100V 直流电, 持续时间 60 ± 5 秒。 100V DC voltage is applied between each pair of terminals, and between the terminal and the metal frame for 60 ± 5 Sec.
4.2 接触电阻 Contact resistance	200 mΩ Max	以 1mA 5V 直流电, 采用点对点测量; 也可用误差不超过 5% 的仪表进行测量, 试验后的电阻取 4 次测量的平均值。 Measured by contact-to-contact method at 1mA Max, 5VDC, Any equipment with error not more than 5% can be used Resistance after test is the average of 4 successive measurements.
4.3 抗电强度 Dielectric Voltage	无击穿现象发生 No dielectric breakdown shall occur	在相互绝缘的所有接线端子之间及各接线端子与外壳或非载流金属零件之间加载 100V (50-60Hz, 泄漏电流 2mA) 交流电, 持续时间 60 ± 5 秒。 100V (50-60HZ, cut-off current 2mA) alternate current load is applied between open terminals and between terminals and the metal frame or between metal parts, for 60 ± 5 Sec.

产品型号 Item.	KS-33C10B060NN-D545	说明 Description	Keyboard Switch	版本 Version	1
页 码 Page	第 3 页 3 of 8		日期 Date	2026-03-12	

5. 机械性能 Mechanical Characteristics:

	项目 Item	标准 Criteria	实验方法 Test Method
5.1	总行程 Total Travel	参见产品图纸 Refer to individual product drawing	按键轴沿操作方向从初始位置到最大行程位置时的距离 The Actuator shall be applied to the tip of actuator in operating direction to change component from free position to end point
5.2	动作行程 Pre Travel		按键轴沿操作方向从初始位置到按键开关动作位置时的距离 The Actuator shall be applied to the tip of actuator in operating direction to change the component to operating position
5.3	操作力 Operating Force		作元件末端沿操作方向均匀施加静载荷, 使操作元件转换到动作位置 A static load shall be applied to the tip of actuator in operating direction to change the component to operating position
5.4	全行程压力 Total Travel Force	<110gf	按键轴沿操作方向从初始位置到最大行程位置时的动作力 The Actuator shall be applied to the tip of actuator in operating direction to change component from free position to end point
5.5	振动试验 Vibration	实验后 After test: -接触电阻:200mΩ Max. -Contact resistance: 200mΩ Max -绝缘电阻:50MΩ Min. -Insulation resistance:50MΩ min - 表面及结构无明显变形 - No abnormalities shall be recognized in appearance and construction.	开关采用常规的安装方法牢固地安装在试验设备上, 并在下述参数条件下进行试验: Switch shall be secured to a testing machine by a normal mounting device and method. Switch shall be measured after following test.: (1) 振频(Vibration frequency range) = <u>10-55</u> Hz (2) 振幅(Total amplitude) = <u>1.5mm</u> (3) 振动变化速率(Sweep ratio): <u>10-55-10Hz</u> 大约 1 分钟(Approx. 1 min.) (4) 变频方法: 对数或线性形式 (Method of changing the sweep vibration frequency: logarithmic or linear) (5) 振动方向: 三个相互垂直的方向, 其中一个方向应是促动元件运动的方向 (Direction of vibration: Three perpendicular directions including actuating direction.) (6) 时间: 每个方向 2 小时(共 6 小时) Duration : 2 hours / direction (6 hours in total)
5.6	冲击试验 Shock		试件在下述参数条件下进行试验: (Switch shall be measured after following test:) (1) 安装方法: 常规方法(Mounting Method: Normal) (2) 加速度(Acceleration) : <u>245m/s² (25G)</u> (3) 时间(Duration) : <u>11ms</u> (4) 实验方向: 图示 6 方向(Test Direction : <u>6</u> directions) (5) 冲击次数: 每个方向 3 次(总共 18 次) Number of shocks : 3 times per direction (18 times in total)

产品型号 Item.	KS-33C10B060NN-D545	说明 Description	Keyboard Switch	版本 Version	1
页 码 Page	第 4 页 4 of 8		日期 Date	2026-03-12	
5.7	可焊性 Solder-Ability	超过 90% 的焊锡面积被焊料所覆盖 More than 90% of immersed part shall be covered with solder.	试件在下述参数条件下进行试验 Key Switch shall be checked after following test: (1) 焊料: 常规; Solder: Normal (2) 焊剂: 质量百分比为 25%松香, 75%甲醇的无色透明溶液; Flux:Rosin Flux having a nominal composition of 25% solids by mass of water white rosin in methyl alcohol solution. (3) 焊接温度: Soldering Temperature: 260 ± 5° C 浸渍时间: Immersing Time:3 ± 1 Sec 焊剂浸渍时间: 5-10 Sec Flux immersing time shall be 5-10s in normal room temperature. (4) 浸渍深度: 接线端应浸到离产品根部 1.5mm 处. Immersion Depth: Immersion depth shall be at copper plating portion of PCB after mounting. (Thickness of PCB=1.5mm)		

6. 寿命试验 Durability Characteristics:

项目 Item	标准 Criteria	实验方法 Test Method
6.1 机械寿命 Mechanical Endurance	实验后 After test: 电气性能应符合第 4.1、4.3 项要求。 Electrical characteristics of items 4.1 、 4.3 shall be satisfied.	在不带负荷的条件下, 在寿命试验设备上连续转换 60,000,000 次, 300 次 /分钟。 60,000,000 cycles of operation shall be performed continuously at a rate of 300 cycles per minute without load.
6.2 负荷寿命 Electronical Endurance	实验后 After test: 电气性能应符合第 4.1、4.3 项要求。 Electrical characteristics of items 4.1 、 4.3 shall be satisfied.	在带以下负荷的条件下, 在寿命试验设备上连续转换 60,000,000 次, 300 次/分。 10mA 12VDC 60,000,000 cycles of operation shall be performed continuously at a rate of 300 cycles per minute with load as follow:10mA 12VDC

7. 耐候性能 Weather Proof Characteristics:

项目 Item	标准 Criteria	实验方法 Test Method
7.1 低温 Cold Proof	实验后 After test: 电气性能应符合第 4.1、4.3 项要求。 Electrical characteristics of items 4.1 、 4.3 shall be satisfied.	试件在 -40±2℃ 的温控箱内保持 96 小时, 然后在正常温度和湿度下恢复 1 小时, 并在此后 1 小时内对试品进行测量, 水滴应消失。 After testing at -40±2℃ for 96 hours, the switch can stay under normal temperature and humidity conditions for 1 hours, and measurement shall be made within 1 hour after that. Water drops shall be eliminated.

产品型号 Item.	KS-33C10B060NN-D545	说明 Description	Keyboard Switch	版本 Version	1
页 码 Page	第 5 页 5 of 8		日期 Date	2026-03-12	
7.2	高温 Hot Proof	实验后 After test: 电气性能应符合第 4.1、4.3 项要求。 Electrical characteristics of items 4.1、4.3 shall be satisfied.	试件在 $80\pm 2^{\circ}\text{C}$ 的温控箱内保持 96 小时，然后在正常温度和湿度下恢复 1 小时，并在此后 1 小时内对试品进行测量。 After testing at $80\pm 2^{\circ}\text{C}$ for 96 hours, the switch can stay under normal temperature and humidity conditions for 1 hours and measurement shall be made within 1 hour after that.		
7.3	恒定湿热 Moisture Resistance		试件在 $40\pm 2^{\circ}\text{C}$ ，90-95%RH 的温控箱内保持 96 小时，然后在正常温度和湿度下恢复 1 小时，并在此后 1 小时内对试件进行测量，水滴应消失。 After testing at $40\pm 2^{\circ}\text{C}$ ，90-95% RH for 96 hours, the switch can stay under normal temperature and humidity conditions for 1 hours, and measurement shall be made within 1 hour after that. Water drops shall be eliminated.		

8. 安装选项 Mounting Options:

安装中板建议选用图示尺寸:
The suggestion dimension of mounting:

9. 材料清单 BOM:

序号 No.	零部件名称 Parts Name	数量 Quantity	材料, 规格 Material and Specifications	防火等级 Prevent fire grade	备注 Remarks
1	胶壳 Cover	1	Thermoplastics		灰白色 Off White
2	底座 Case	1	Thermoplastics		蓝色 Blue
3	键轴 Actuator	1	Thermoplastics		蓝色 Blue
4	导光柱 Light guide	1	Thermoplastics		透明 Transparent
5	弹簧 Spring	1	Stainless Steel		
6	接触片 Movable plate	1	Copper Alloy		
7	端子 Terminal	2	Copper Alloy		
8	触点 Contact	1	Au Alloy		
9	发声片 Spring plate	1	Stainless Steel		

注意事项 Precautions for use:

1. 一般事项 General:

本产品主要用于自动化装置，视像装置，家用电器，信息装置及通讯装置等常用电子设备中；如果该产品要用于其它具有更高安全性及可靠性的耐久性设备中（如生命维持装置，宇宙航空装置，防灾及安全性装置）时，请确认是否合用，或者同我方了解详细情况。

The product is used mainly in electronic devices such as automotive devices, visual devices, home electrical appliances, information devices and communication settings. If the products is intended to be used for other endurance equipments requiring higher safety and reliability such as life support system, space and aviation devices, disaster and safety system, it's necessary to make verification of conformity or contact us for the details before using.

2. 焊接安装 Soldering and assembly:

产品型号 Item.	KS-33C10B060NN-D545	说明 Description	Keyboard Switch	版本 Version	1
页 码 Page	第 6 页 6 of 8		日期 Date	2026-03-12	

(1) 焊锡条件应按照实际的对应条件予以确认。

The soldering conditions should be confirmed according to the actual production environment.

(2) 焊锡工序完成后，不要尝试用溶剂或类似物品清洗开关。

Don't try to clean the switch with a solvent or similar substance after the soldering process.

(3) 开关焊锡后，还有热量时，请不要操作开关。

Don't operate the switch if it still has heat after soldering.

(4) 如使用水溶性助焊剂，可能会导致开关破损，因此应确保不要用这种助焊剂。

The switch might be damaged if using the water-soluble flux, so make sure not to use such kind of flux.

3. 安装构造，机械设计 Assembly structure and Mechanical design:

(1) 线路板上安装孔及安装图示的尺寸都须参照工程图中所建议的尺寸。

The dimensions for the holes and the pattern on PCB should refer to the recommended dimensions on the engineering drawing.

(2) 如果施超出规定值的较大重力于开关上，会导致开关破损，所以应特别小心防止开关承受超出规定值的较大重力。

The switch might be broken if there is stress stronger than the specified is given on it. Take special care not to stress the switch beyond its specification.

(3) 把本公司的产品和其它产品配合使用时，请客户确认必须适合的规格、法规或规定。另请客户自身确认本公司产品装到客户使用的系统、机械、装置上的适用性. 如果想变更开关使用条件，请预先与本公司进行协商。

If the switch is being used together other products, please confirm the compatibility of the specification, laws and regulations. Please also confirm the compatibility of switch to be installed in the systems, machines and devices used by customer. If you want to change the operating conditions of the switch, please consult with us in advance.

4. 使用环境 Operating Environment

(1) 如果该产品常用于产生硫化气体的硫性热源周围或有汽车废气存在的地方，应特别留意，因为开关性能可能会受到影响；

If the product is always used near sulfurate hot spring where sulfide gas is generated or in a place where exhaust gas from automobiles exists, it's necessary to pay more attention because the switch performance may be affected.

(2) 如果在安装开关的模组内有以下所描述的部件材料，需遵循以下要求：

If the below parts or materials are used in the module where the switch is installed, directions below should be followed:

A. 部品、橡胶材料、粘合剂、包装材料及用于装置内机械部件上的润滑油剂等，不要使用那些可能会产生硫化气体或氧化气体的材料。

For parts, rubber materials, adhesive agents, packing material and grease used for the mechanical part of the device, don't use any material that may generate gas of sulfurization or oxidization.

B. 当有用到磷橡胶、润滑油、粘合剂及油脂时，应使用不会产生低分子磷氧烷气体的材料，因为低分子磷氧烷气体会在开关接触部位形成二氧化磷层从而引起接触不良，如有用到（如涂料剂等化学溶剂），请预先告知我方。

If silicon rubber, grease, adhesive agents and oil are used, choose the material that will not generate low molecular siloxane gas, because the low molecular siloxane gas may form silicon dioxide coat on the switch contact part, resulting of failing contact.

(3) 不要将开关用于高湿或有沾湿可能性的环境中，因这样的环境可能会引起端子间电流泄漏。

Don't use the switch in the environment with high humidity or other bedewing possibility, as it may cause leaking among the terminals.

(4) 外部浸入物的影响: 由于该开关无密封机构，因此可能会由于外部环境中浸入的尘埃而引起接触失效，在使用该开关时，应采取防尘措施，以下是尘埃浸入的范例，使用时请注意防止：

The effect caused by outer immersed dust: Because the switch was designed without dust-proof structure, it may have failing contact due to the immersed dust from the outer environment. When using the switch, it's necessary to take dust-proof actions. Examples of immersed dust, which should be prevented during the operation:

A. 加工过程中切口处及 PCB 孔处产生碎屑，或 PCB 防护材料，（如报纸、发泡、聚苯乙烯材料等）产生的废弃物等浸入开关内。

The scraps being generated during PCB processing, or other waste from the protective material for PCB such as newspaper, foam, polystyrene materials, may immerse inside the switch.

B. 在堆叠 PCB 时产生的助焊剂或粉末状焊剂浸入开关内。

The flux or solder powder being generated when stacking the PCB may immerse inside the switch.

5. 保存方法 Storage Method:

产品型号 Item.	KS-33C10B060NN-D545	说明 Description	Keyboard Switch	版本 Version	1
页 码 Page	第 7 页 7 of 8		日期 Date	2026-03-12	

(1) 为防止本产品的性能劣化和耐焊性等性能受到影响，请保管在以下的条件和环境下：

In order to protect the switch performance and the soldering conditions, it should keep the switch under the following conditions:

A. 温度 -40C 以上, +80C 以下, 湿度 85% 以下的环境。

Temperature of -40C to +80C, with humidity lower than 85%RH;

B. 避免保存在含有腐蚀性气体等的空气中。

Avoid storing in the environment containing corrosive gas;

C. 产品购入后, 不可超过 6 个月以上长期保管。

After purchasing, the storage period should not exceed 6 months.

D. 避免保存在日光能直射的场所。

Avoid keeping it in the location with direct sunlight.

(2) 在不施加负重外力的包装状态下进行保管。

Store using the standard packing without exerting force.

(3) 保存标准为 3 个月, 限度为 6 个月以内, 请尽早使用。打开包装后, 有剩余品时, 应将剩余部分以胶袋包装好以同外界隔离, 请进行合适的防湿, 防腐蚀气体等处理后进行保管。

The standard storage period is 3 months, with maximum up to 6 months, preferably to be used as soon as possible.

After opening the package, you should put the remaining switches in a plastic bag to prevent from damp and corrosive gas.

6. 其它 Others:

请特别注意严格遵守以下的禁止事项及注意事项 Please take good care to comply with the following guidelines:

(1) 关于火灾, 冒烟的禁止事项 The prohibited practices where there is fire and fume:

A 超过额定负荷使用时, 有发生火灾的可能性, 故请切勿超负荷使用。

It might catch fire if the rating exceeds the specifications. Never use the switch beyond the rating.

B 如果有误使用、异常使用等有可能超过额定电流的话, 请采取对策。如:通过设置保护电路等切断电流。

If the rating may exceed due to some abuse or abnormal usage, please take protective measures such as protective circuit to shut down the circuit.

(2) 对于追求安全性产品的注意事项 Precautions to the products requiring special safety:

A 对于产品品质我司以期万全, 但有可能发生寿命等故障形式, 如性能劣化、短路、常开等。因此, 在设计追求安全性产品的时候: “对于零件单一故障, 产品会出现什么故障”。请进行事前检讨。

Though we are confident in switch quality, we can't deny the possibility that there could be failure due to inferior performance, short or open circuit. Therefore, when designing the product requiring special safety, please verify in advance what effects would show on your product in case the switch alone may fail.

B 准备保护电路、保护装置的系统以谋求安全。

Prepare the system with protective circuit and protective devices for safety purposes.

C 准备安全备用电路, 使单一的故障不会导致整体系统的失效, 以确保安全性。

Prepare safety standby circuit to preclude the whole system failure that may result from specific failure.

(3) 动作力曲线, 轻柔触感动作 Force travel diagram, soft tactile action:

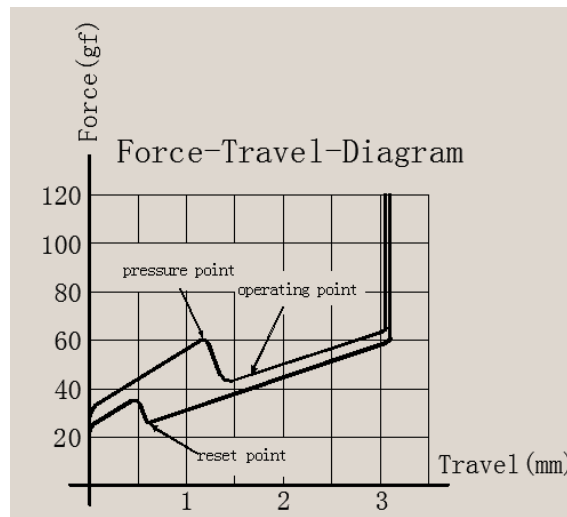

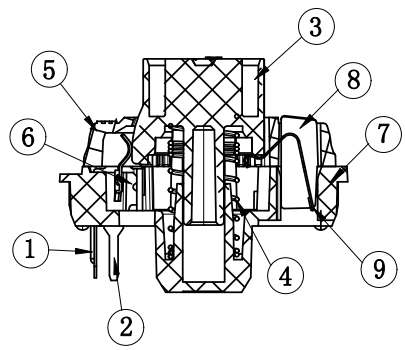
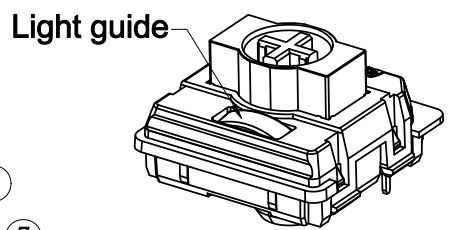
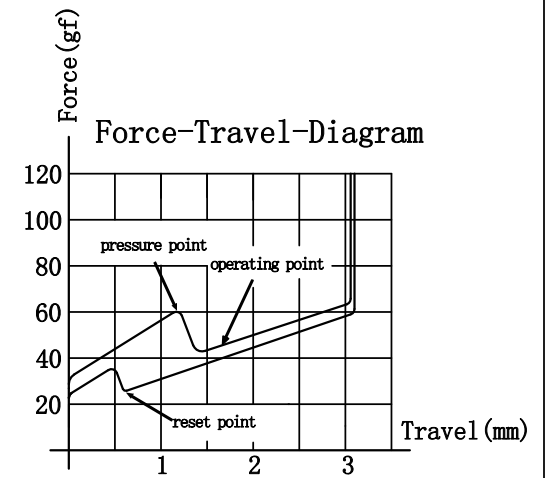
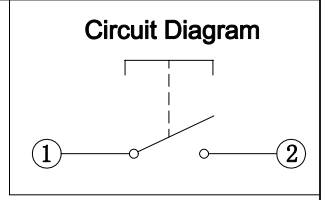
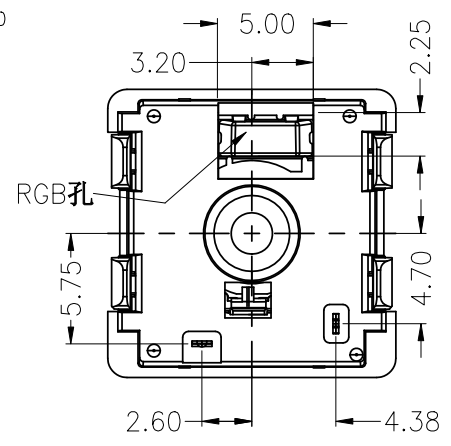
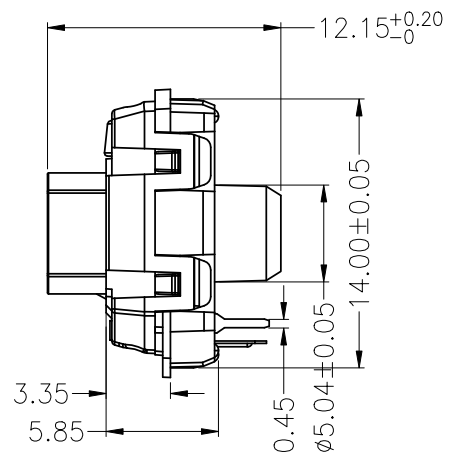
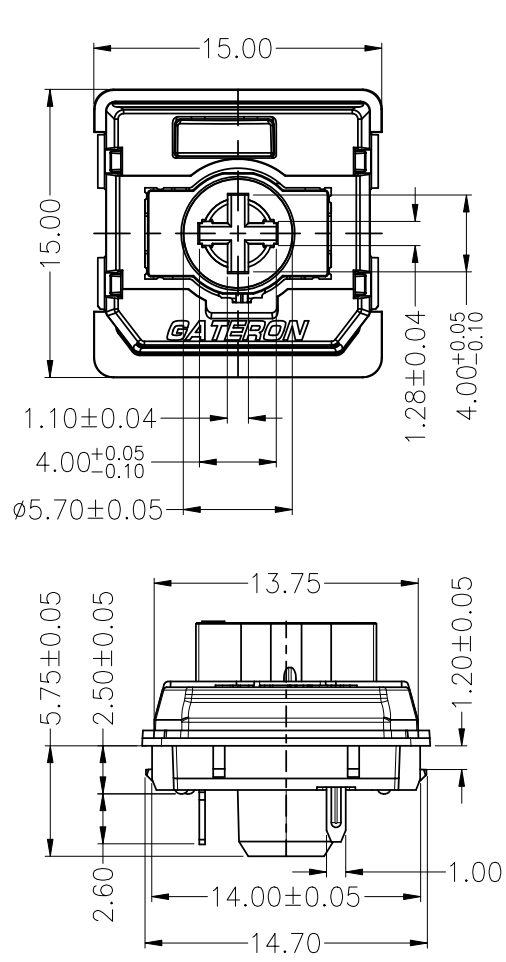

⑨	Spring plate	Stainless Steel
⑧	Light guide	Thermoplastics(transparent)
⑦	Case	Thermoplastics(Blue)
⑥	Contact	Au Alloy
⑤	Cover	Thermoplastics(Off White)
④	Spring	Stainless steel
③	Actuator	Thermoplastics(Blue)
②	Terminal	Copper alloy
①	Movable plate	Copper alloy
ITEM	Part Name	Material

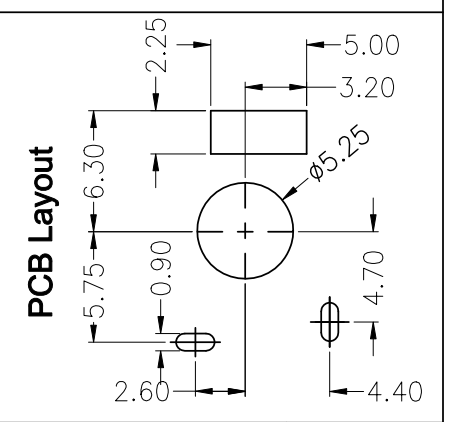

Notes:
 There is a slight oil overflow in the lubed switch, which is a normal phenomenon.
 Please choose it carefully.

Specification:
 1.Rating:12VAC Max. 2VDC Min. 10mA AC/DC Max,10µA DCMin.
 2.Contact Resistance: 200mΩ Max.
 3.Insulation Resistance:100MΩ Min(DC100V).
 4.Wichstand Voltage: AC100V(50~60Hz) for 1 minute.
 5.Bounce Time: 5msec Max.(at 16 in/sec. actuation speed).
 6.Operation Force: 60±15gf.
 7.Pre travel: 1.7^{+0.5}/_{0.25}mm.
 8.Total travel: 3.0±0.2mm
 9.Operation Life: 60,000,000 Cycles(min)

REV.	DATE	MODIFICATION	PRIOR VERSION
Title/Proj		KS-33 Switch	
Tolerance Unless Otherwise Specified			
Part No	KS-33C10B060NN-D545	Version	1
Drawing No	KS-33C10B060NN-D545	Scale	5:2
Drafted by	Wang Bolin	Date	2026-03-12
Checked by	Fu Dong	Date	2026-03-12
Approved by	He Shiyong	Date	2026-03-12
Unit: mm		Size: A4	
THIRD ANGLE			
 GATERON GATERON Electronic Technology Co.,Ltd			

佳达隆电子科技有限公司

KS-27&33&33B&33G&33F 系列包装标准		版 本	页 次
文件编号	SOP-KS-27-001	M001	第 1 页 共 1 页

KS 系列包装方式:

序号	名 称	料号	规格/mm	数 量	序号	名 称	规格/mm	数 量
1	外箱	P-WX-002	480X245X250	1	4	产品	KS-27 矮轴键盘开关	1600PCS/盒
2	吸塑盒	P-VF-301	228*228*120	4	5	产品	KS-27 矮轴键盘开关	6400PCS/箱
3	吸塑盖	P-VF-300	228*228*10	4				



一、每盒 1600pcs



二、盖上盒盖，每箱放 4 盒



三、透明胶带封装



四、贴上环保和出货标签

注:每卡板最多叠放 6 层外箱。

发布日期	实施日期	签 章	编制	审核	批准
2024-10-24	2024-10-24		巫福荣	何时英	宋建青