

GATERON

Product Specification

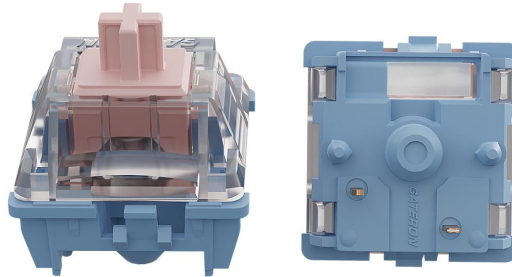

GATERON Product Name:

Keyboard Switch(Melodic Switch)

GATERON Item No.:

KS-61BFH10B060NW-D165 (自润)

1. General Characteristics:

1.1 Application : This specification is applied to the switch for general applications.

1.2 Operating Temperature Range : -40 °C to +80 °C

1.3 Operating Relative Humidity Range : $\leq 85\%$ RH, +40 °C

1.4 Test Conditions :

Unless otherwise specified, the atmospheric conditions for making measurements and tests are as follows:

Ambient Temperature : 5-35 °C

Air Pressure : 86-106 Kpa

Relative Humidity : 45-85% RH

2. Appearance, Structure and Dimensions:

2.1 Appearance : The switch shall have good finishing, and no rust, crack or plating defects.

2.2 Structure and Dimensions : Refer to individual product drawing.

2.3 Markings : Refer to individual product drawing.

3. Ratings : 10mA 12VDC (Resistance load)

4. Electrical Characteristics:

	Item	Criteria	Test Method
4.1	Insulation Resistance	100M Ω Min.	100V DC voltage is applied between each pair of terminals, and between the terminal and the metal frame for 60 \pm 5 Sec.
4.2	Contact resistance	200 m Ω Max	Measured by contact-to- contact method at 1mA Max,5VDC,Any equipment with error not more than 5% can be used Resistance after test is the average of 4 successive measurements.

4.3	Dielectric Voltage	No dielectric breakdown shall occur	100V(50-60HZ,cut –off current 2mA)alternate current load is applied between open terminals and between terminals and the metal frame or between metal parts, for 60 ± 5 Sec.
-----	--------------------	-------------------------------------	---

5. Mechanical Characteristics:

	Item	Criteria	Test Method
5.1	Total Travel	Refer to individual product drawing	The Actuator shall be applied to the tip of actuator in operating direction to change component from free position to end point
5.2	Pre Travel		The Actuator shall be applied to the tip of actuator in operating direction to change the component to operating position
5.3	Operating Force		A static load shall be applied to the tip of actuator in operating direction to change the component to operating position
5.4	Total Travel Force	< 110gf	The Actuator shall be applied to the tip of actuator in operating direction to change component from free position to end point
5.5	Vibration	After test: -Contact resistance: 200mΩ Max -Insulation resistance:50MΩ min - No abnormalities shall be recognized in appearance and construction.	Switch shall be secured to a testing machine by a normal mounting device and method. Switch shall be measured after following test: (1)(Vibration frequency range)= <u>10-55Hz</u> (2)(Total amplitude)= <u>1.5mm</u> (3)(Sweep ratio): <u>10-55-10Hz</u> (Approx. 1 min.) (4)(Method of changing the sweep vibration frequency : logarithmic or linear) (5)(Direction of vibration: Three perpendicular directions including actuating direction.) (6)Duration : 2 hours / direction (6 hours in total)
5.6	Shock	After test: -Contact resistance: 200mΩ Max -Insulation resistance:50MΩ min - No abnormalities shall be recognized in appearance and construction.	(Switch shall be measured after following test:) (1)(Mounting Method: Normal) (2)(Acceleration) : <u>245m/s² (25G)</u> (3)(Duration) : <u>11ms</u> (4)(Test Direction : <u>6</u> directions) (5)Number of shocks : 3 times per direction (18 times in total)

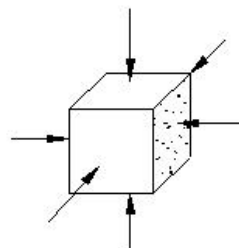

5.7	Solder-Ability	More than 90% of immersed part shall be covered with solder.	<p>Key Switch shall be checked after following test:</p> <p>(1)Solder: Normal (2)Rosin Flux having a nominal composition of 25% solids by mass of water white rosin in methyl alcohol solution. (3)Soldering Temperature: $260 \pm 5^{\circ}\text{C}$ Immersing Time:3 ± 1 Sec 5-10 Sec Flux immersing time shall be 5-10s in normal room temperature. (4)Immersion Depth: Immersion depth shall be at copper plating portion of PCB after mounting. (Thickness of PCB=1.5mm)</p>
-----	----------------	--	--

6.Durability Characteristics:

X	Item	Criteria	Test Method
6.1	Mechanical Endurance	After test: Electrical characteristics of items 4.1 、 4.3 shall be satisfied.	80,000,000 cycles of operation shall be performed continuously at a rate of 300 cycles per minute without load.
6.2	Electronical Endurance		80,000,000 cycles of operation shall be performed continuously at a rate of 300 cycles per minute with load as follow:10mA 12VDC.

7. Weather Proof Characteristics:

X	Item	Criteria	Test Method
7.1	Cold Proof	After test: Electrical characteristics of items 4.1 、 4.3 shall be satisfied.	After testing at $-40 \pm 2^{\circ}\text{C}$ for 96 hours, the switch can stay under normal temperature and humidity conditions for 1 hours, and measurement shall be made within 1 hour after that. Water drops shall be eliminated.
7.2	Hot Proof	After test: Electrical characteristics of items 4.1 、 4.3 shall be satisfied.	After testing at $80 \pm 2^{\circ}\text{C}$ for 96 hours, the switch can stay under normal temperature and humidity conditions for 1 hours and measurement shall be made within 1 hour after that.
7.3	Moisture Resistance		After testing at $40 \pm 2^{\circ}\text{C}$, 90-95% RH for 96 hours, the switch can stay under normal temperature and humidity conditions for 1 hours, and measurement shall be made within 1 hour after that. Water drops shall be eliminated.

8. Mounting Options:

The suggestion dimension of mounting:

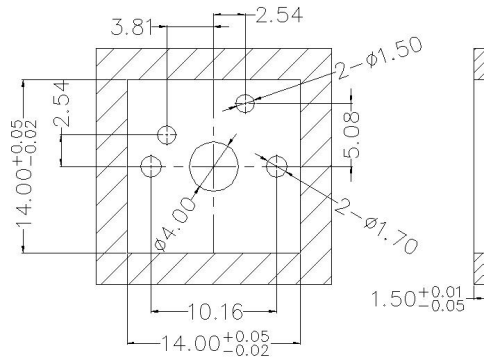

9.BOM:

No.	Parts Name	Quantity	Material and Specifications	Prevent fire grade	Remarks
1	Cover	1	Thermoplastic		Translucent pink
2	Case	1	Thermoplastic		Pastel blue
3	Actuator	1	Thermoplastic		Pink
4	Double-Section Spring	1	Stainless steel		
5	Contact blade	1	Copper alloy		
6	Terminal	1	Copper alloy		
7	Contact	2	Au alloy		

Precautions for use:

1.General: The product is used mainly in electronic devices such as automotive devices, visual devices, home electrical appliances, information devices and communication settings. If the products is intended to be used for other endurance equipments requiring higher safety and reliability such as life support system, space and aviation devices, disaster and safety system, it's necessary to make verification of conformity or contact us for the details before using.

2.Soldering and assembly:

- (1) The soldering conditions should be confirmed according to the actual production environment.
- (2) Don't try to clean the switch with a solvent or similar substance after the soldering process.
- (3) Don't operate the switch if it still has heat after soldering.
- (4) The switch might be damaged if using the water-soluble flux, so make sure not to use such kind of flux.

3.Assembly structure and Mechanical design:

- (1) The dimensions for the holes and the pattern on PCB should refer to the recommended dimensions on the engineering drawing.
- (2) The switch might be broken if there is stress stronger than the specified is given on it. Take special care not to stress the switch beyond its specification.
- (3) If the switch is being used together other products, please confirm the compatibility of the specification, laws and regulations. Please also confirm the compatibility of switch to be installed in the systems, machines and devices used by customer. If you want to change the operating conditions of the switch, please consult with us in advance.

4.Operating Environment:

- (1) If the product is always used near sulfurate hot spring where sulfide gas is generated or in a place where exhaust gas from automobiles exists, it's necessary to pay more attention because the switch performance may be affected.
- (2) If the below parts or materials are used in the module where the switch is installed, directions below should be followed:
 - A.For parts, rubber materials, adhesive agents, packing material and grease used for the mechanical part of the device, don't use any material that may generate gas of sulfurization or oxidization.
 - B.If silicon rubber, grease, adhesive agents and oil are used, choose the material that will not generate low molecular siloxane gas, because the low molecular siloxane gas may form silicon dioxide coat on the switch contact part, resulting of failing contact.
- (3) Don't use the switch in the environment with high humidity or other bedewing possibility, as it may cause leaking among the terminals.

(4) The effect caused by outer immersed dust: Because the switch was designed without dust-proof structure, it may have failing contact due to the immersed dust from the outer environment. When using the switch, it's necessary to take dust-proof actions.

Examples of immersed dust, which should be prevented during the operation:

A. The scraps being generated during PCB processing, or other waste from the protective material for PCB such as newspaper, foam, polystyrene materials, may immerse inside the switch.

B. The flux or solder powder being generated when stacking the PCB may immerse inside the switch.

5.Storage Method:

(1) In order to protect the switch performance and the soldering conditions, it should keep the switch under the following conditions:

A. Temperature of -40C to +80C, with humidity lower than 85%RH;

B. Avoid storing in the environment containing corrosive gas;

C. After purchasing, the storage period should not exceed 6 months.

D. Avoid keeping it in the location with direct sunlight.

(2) Store using the standard packing without exerting force.

(3) The standard storage period is 3 months, with maximum up to 6 months, preferably to be used as soon as possible. After opening the package, you should put the remaining switches in a plastic bag to prevent from damp and corrosive gas.

6. Others: Please take good care to comply with the following guidelines:

(1) The prohibited practices where there is fire and fume:

A. It might catch fire if the rating exceeds the specifications. Never use the switch beyond the rating.

B. If the rating may exceed due to some abuse or abnormal usage, please take protective measures such as protective circuit to shut down the circuit.

(2) Precautions to the products requiring special safety:

A. Though we are confident in switch quality, we can't deny the possibility that there could be failure due to inferior performance, short or open circuit. Therefore, when designing the product requiring special safety, please verify in advance what effects would show on your product in case the switch alone may fail.

B. Prepare the system with protective circuit and protective devices for safety purposes.

C. Prepare safety standby circuit to preclude the whole system failure that may result from specific failure.

(3) Force travel diagram, soft tactile action:

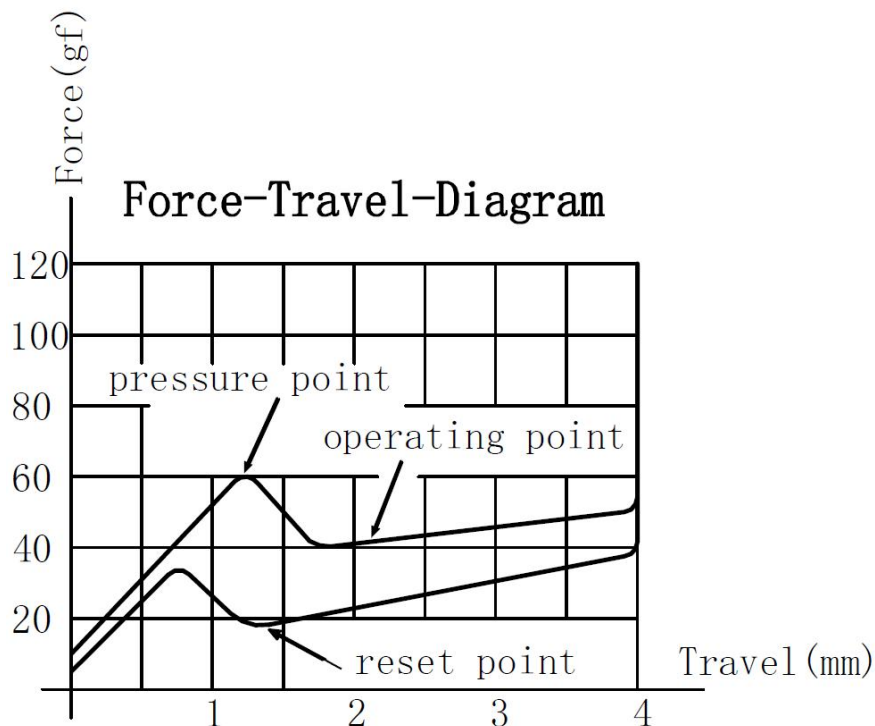

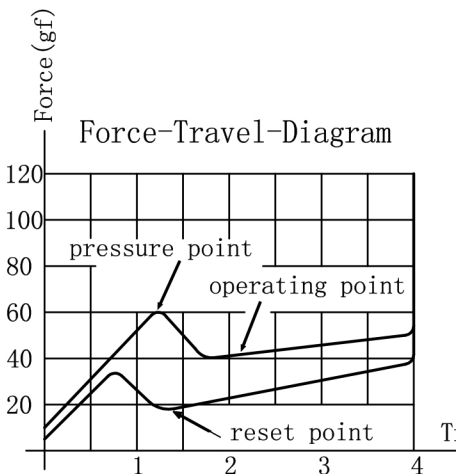
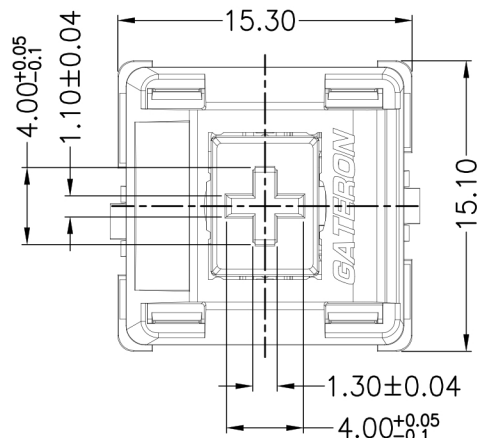

Layout of PCB

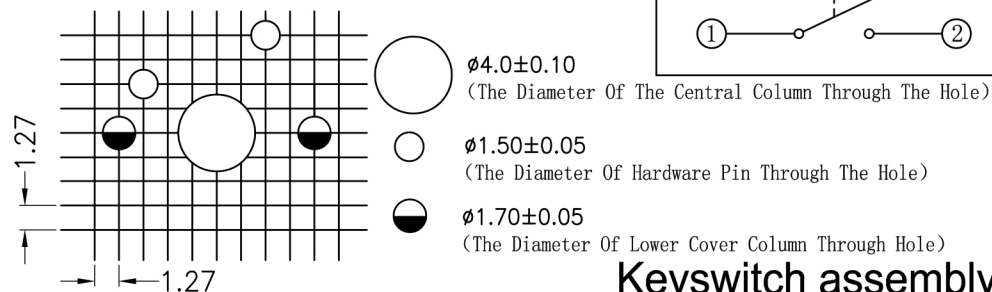

Circuit Diagram

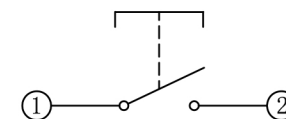

Keyswitch assembly

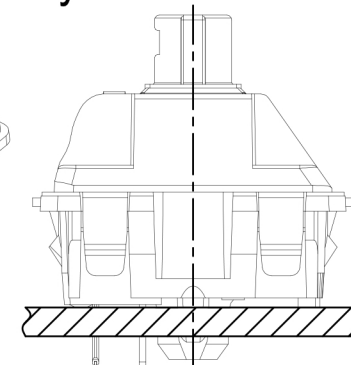
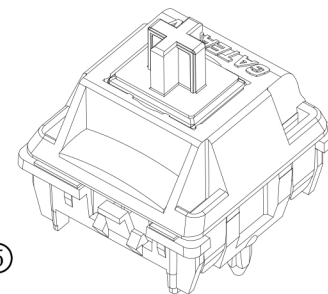
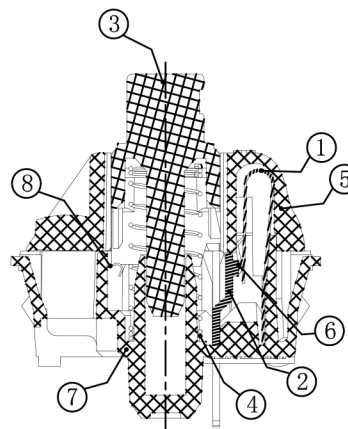
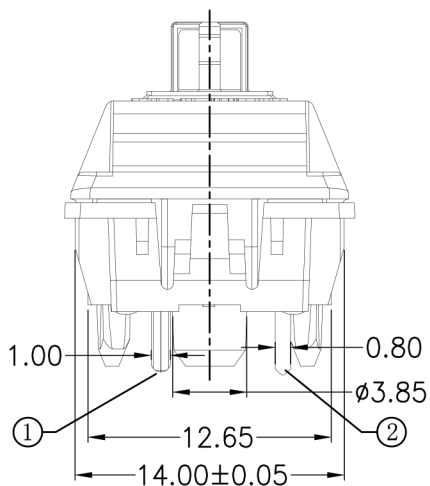
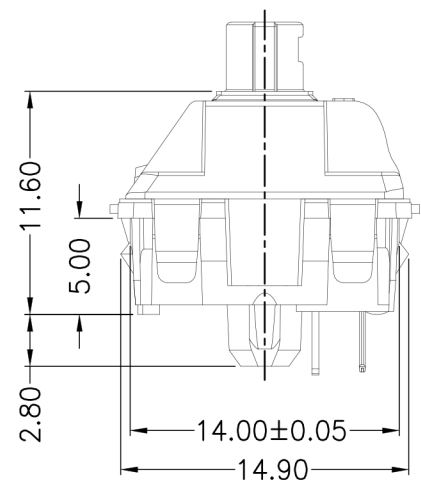

with pins

⑧	Spring plate	Stainless steel
⑦	Case	Thermoplastic(Pastel bule)
⑥	Contact	Au Alloy
⑤	Cover	Thermoplastic(Translucent pink)
④	Spring	Stainless steel
③	Actuator	Thermoplastic(Pink)
②	Static plate	Copper alloy
①	Movable plate	Copper alloy
ITEM	Part Name	Material

Specification:

- Rating: 12VAC/DC Max. 2VDC Min. 10mA AC/DC Max, 10µA DCMIn.
- Contact Resistance: 200mΩ Max.
- Insulation Resistance: 100MΩ Min(DC100V).
- Wichstand Voltage: AC100V(50~60Hz) for 1 minute.
- Bounce Time: 5msec Max.(at 16 in/sec. actuation speed).
- Operation Force: 60±12gf.
- Pretravel: 2.0^{+0.6}_{-0.2}mm.
- Total travel: 4.0mm Max.
- Operation Life: 60,000,000 Cycles(min)

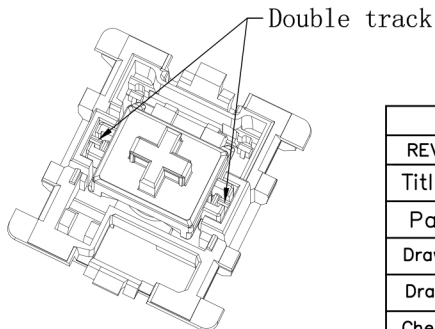

REV.	DATE	MODIFICATION							PRIOR VERSION
Title/Proj		KS-61B SERIES 空灵轴(自润)			Tolerance Unless Otherwise Specified				
Part No	KS-61BFH10B060NW-D165	Version	1	~3	>3~10	>10~30	>30~80	>80~180	Angle
Drawing No	KS-61BFH10B060NW-D165	Scale	1:1	±0.2	±0.3	±0.4	±0.6	±0.8	±3'
Drafted by	Deng Yuqin	Date	2023-12-09	Unit: mm		Size: A4	SHEET 1 OF 1		
Checked by	Wu Furong	Date	2023-12-09	THIRD ANGLE		 GATERON GATERON Electronic Technology Co.,Ltd			
Approved by	He Shiyang	Date	2023-12-09						